

envirovent

Eco dMEV+
Eco dMEV+ 17V



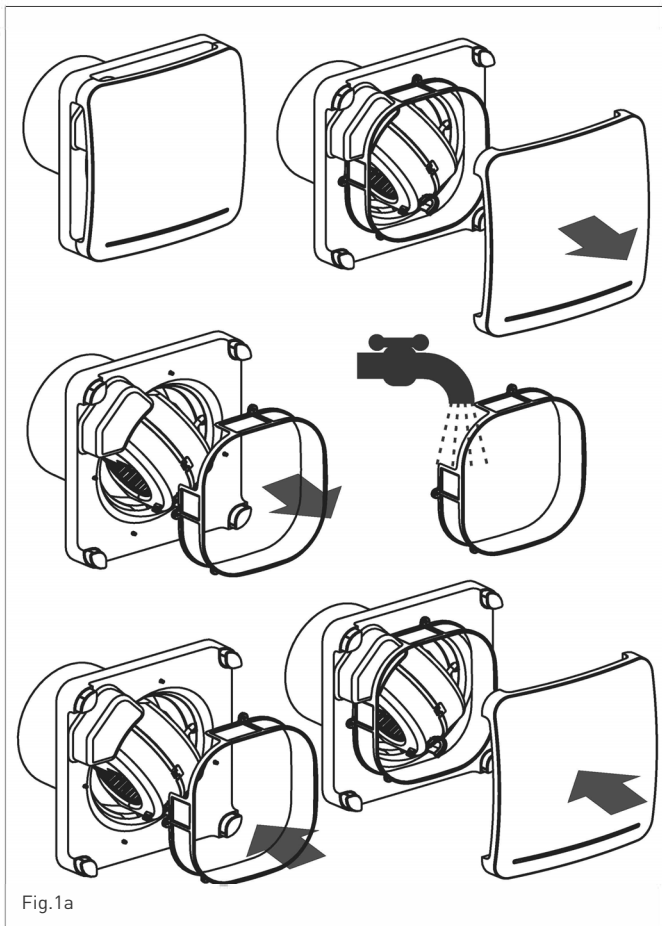
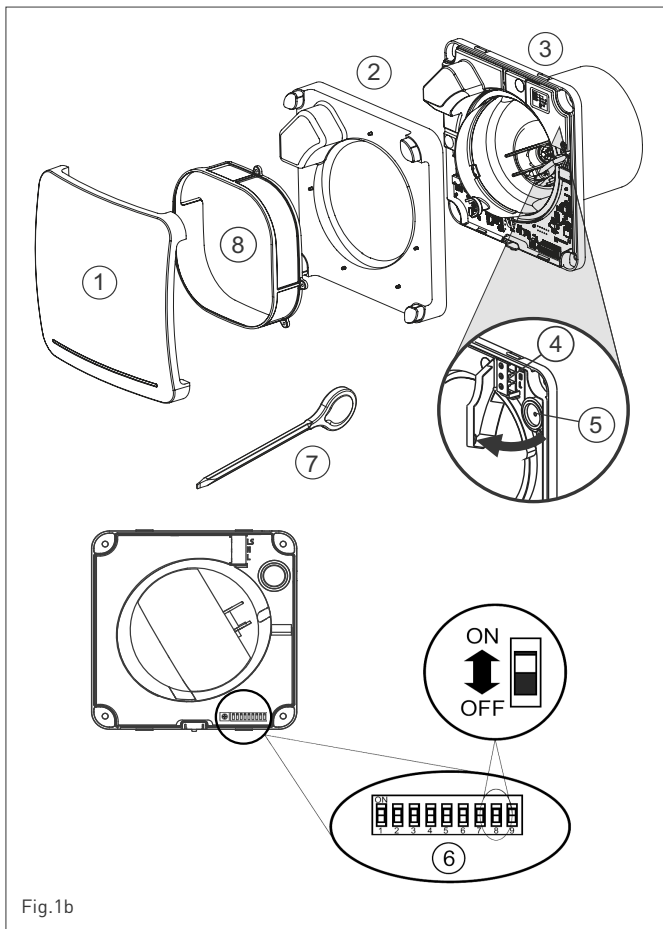

Fig.1a



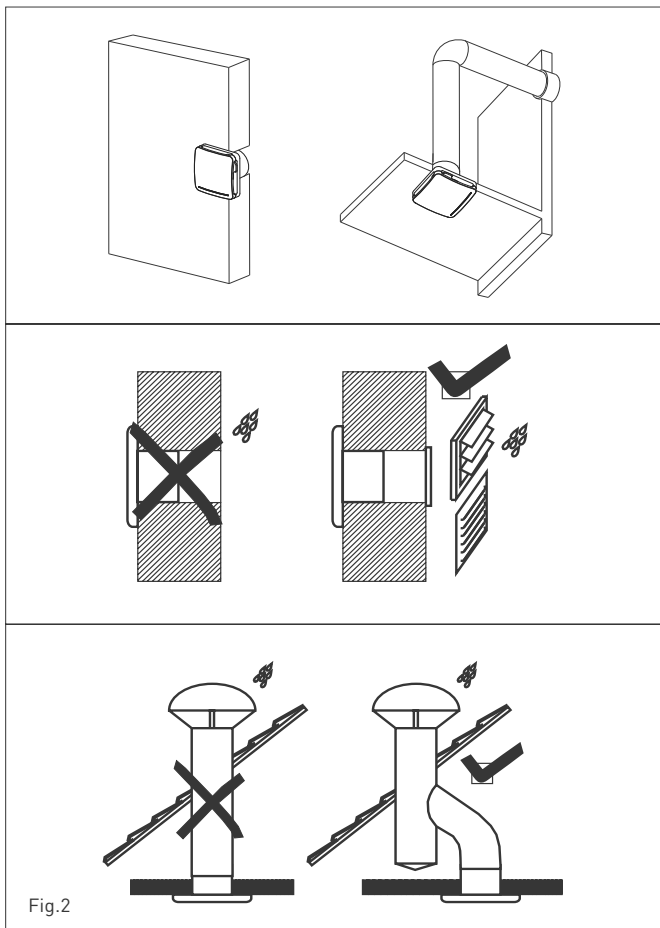
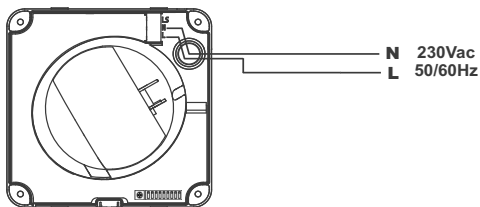

Fig.2

Eco dMEV+



Eco dMEV+ 17V

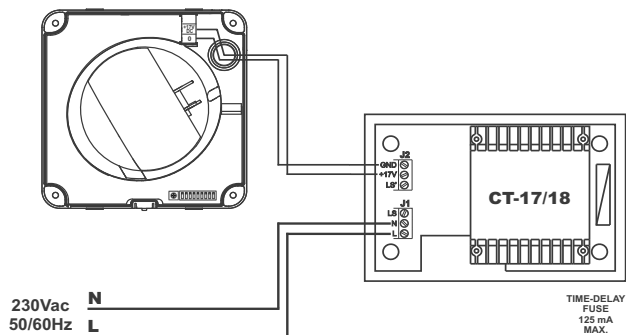
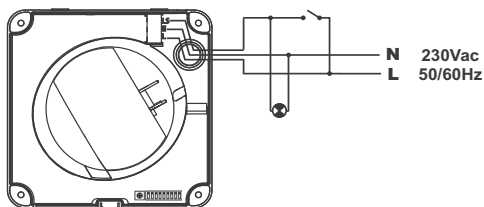

Fig.3

Eco dMEV+



Eco dMEV+ 17V

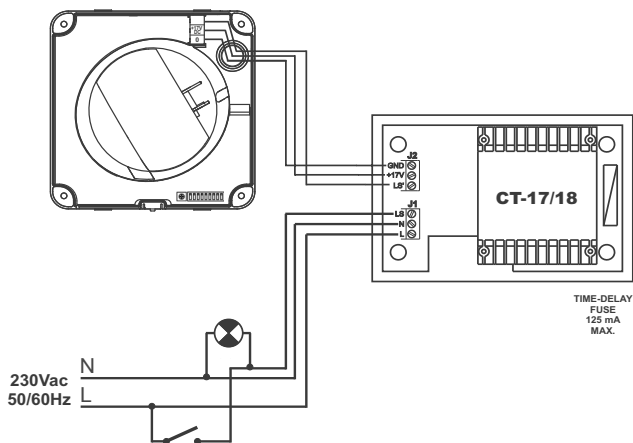
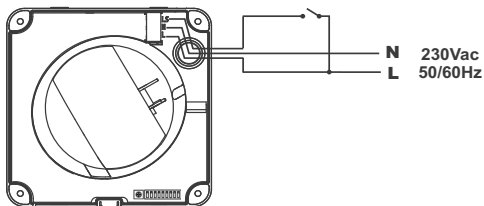

Fig.4

Eco dMEV+



Eco dMEV+ 17V

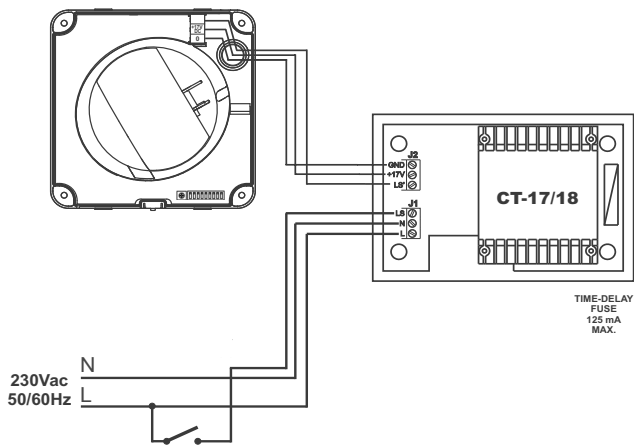
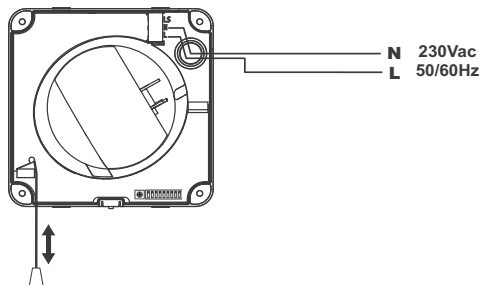

Fig.5

Eco dMEV+



Eco dMEV+ 17V

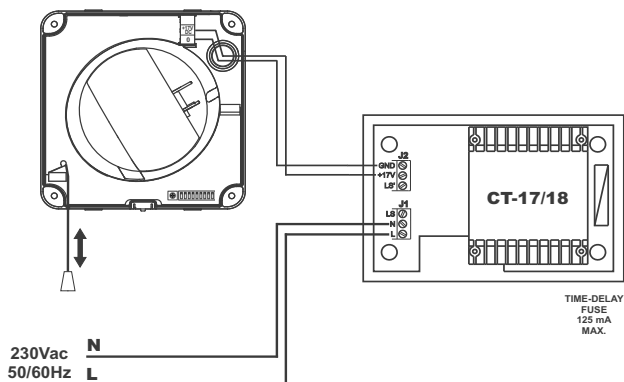

Fig.6

Eco dMEV+ Centrifugal Extract Fan

The Eco dMEV+ extract fan range is manufactured to the highest standards of production and quality as laid down by the international Quality Standard ISO 9001. All components have been checked and every one of the final products will have been individually tested at the end of the manufacturing process.

On receipt of the product we recommend that you to check the following:

1. That it is the correct model.
2. That the details on the rating label are those you require: voltage, frequency...

The installation must be carried out in accordance with Building Regulations and the current I.E.E. wiring regulations (BS7671) or the equivalent standards in force in your country.

This appliance can be used by children aged from 8 years and above and persons with reduced physical, sensory or mental capabilities or lack of experience and knowledge if they have been given supervision or instruction concerning

use of the appliance in a safe way and understand the hazards involved. Children shall not play with the appliance. Cleaning and user maintenance shall not be made by children without supervision.

INSTALLATION

IMPORTANT: Before installing and wiring the unit, ensure that the mains supply is disconnected.

Fig. 1b:

1. Front grille
2. Protection cover
3. Support
4. Connection terminals
5. Cable entry
6. Dip switches
7. Setting tool
8. Air filter

The Eco dMEV+ is suitable for wall or ceiling mounting and can either extract directly to the outside or through a ducted system (see Fig. 2).

Make a Ø105 mm hole in the wall or ceiling.

If the unit is to be installed with ducting, use a standard Ø100 mm duct.

Remove the front grille (1) and the protection cover (2).

The unit can be mounted on the wall or ceiling using the 4 raw plugs and the screws provided.

Ensure that there are no obstructions to the airflow and that the impeller turns freely.

Introduce the mains cable through the cable entry (5) and fix it to the wall.

Connect the electrical wiring as set out below and then mount the protection cover and the front grille.

ELECTRICAL CONNECTION

The Eco dMEV+ is an extract fan designed for a single phase supply, with voltage and frequency as indicated on the rating plate of the unit. The units are manufactured with double electrical insulation (Class II) and therefore they do not need an earth connection. The electrical installation must include a double pole switch with a contact clearance of at least 3 mm.

The electrical cable must enter the Eco dMEV+ through the cable entry (5).

Once the cable has been introduced proceed using the electrical wiring diagram applicable to the selected model.

OPERATION

The Eco dMEV+ is an extract fan designed to operate continuously at low speed and constant volume. The constant flow setting is made with dip-switches placed on the electronic circuit board (Fig. 1b):

Constant volume		SW dip switch position		
m ³ /h	l/s	SW2	SW3	SW4
14	4	OFF	OFF	OFF
18	5	ON	OFF	OFF
29	8	OFF	ON	OFF
40	11	ON	ON	OFF
47	13	OFF	OFF	ON
65	18	ON	OFF	ON

The Eco dMEV+ may also operate at high speed that is activated by: an external switch live or light switch (**S, T and HT versions**) an integral humidity sensor (**HT and HTP versions**) or an internal pull cord switch (**HTP version**).

ECO DMEV+ S

The Eco dMEV+ S can operate in two modes:

Continuous operation on trickle setting only (Fig. 3). Once the air volume is set the fan is connected to the mains and the unit will operate continuously at this air volume.

Continuous operation on trickle with the ability to boost on high speed.

The Eco dMEV+ is connected to an external switch or light switch.

When the switch is pressed, the fan operates on full speed (not constant) until the switch is turned off (light off): Fig.4- Wiring diagram to boost the fan with the light switch.

Fig.5- Wiring diagram to boost the fan with a separate switch

ECO DMEV+ T

This model is provided with an adjustable over-run timer. The timer allows the fan to continue to operate for the selected period after the switch has been turned off (fig.5).

Fig.4 shows how to connect the fan with timer through using the same switch as the lighting circuit to allow the fan to be boosted.

To set the timer, is done through switch 6 and 7.

SW6	SW7	TIMER (Minutes)
OFF	OFF	1
ON	OFF	5
OFF	ON	15
ON	ON	30

ECO DMEV+ HT

Models provided with an electronic humidity sensor which can be adjusted from 60% to 90 % RH (relative humidity) and with a timer, adjustable between 1 and 30 minutes. To set the humidity sensor is done through SW8 and SW9.

SW8	SW9	HR Setpoint (%)
OFF	OFF	60
ON	OFF	70
OFF	ON	80
ON	ON	90

OPERATION

Case 1: Automatic operation (fig.3). In automatic operation, the extract fan

operates continuously on the trickle setting speed. When the humidity level in the room is higher than the set level the fan will boost to high speed. When the humidity drops below the selected level and after the selected period set on the timer the fan automatically returns to trickle.

Case 2: Automatic operation as in case 1 with the facility to override the humidity sensor by means of an external switch (fig.5) or light switch (fig.4), when the humidity level in the room is lower than the selected level. In this case, the extract fan continues to operate for the selected period set on the timer after the light switch has been turned off.

ATTENTION: When the humidity rate is above the selected value, the automatic option takes precedence over the manual.

FACTORY SETTINGS

- Airflow: (8l/s)
- Timer: 1 minute
- Humidity: 60% RH

SPECIFIC RECOMMENDATIONS

- If you change the settings of the extract fan you have to handle the microswitches in the printed circuit board. These microswitches are fragile and must be handled with care.
- Do not change the setting of the humidity sensor out of the room where the fan will be installed.

- If the humidity is always above 90% RH, the fan will always run at full speed.
- If the humidity in the room is always less than 60%, the fan will only operate on trickle speed when running in automatic operation.

If the fan never runs on boost:

- The setting of the humidity sensor has been set to maximum. Change the setting.
- The level of humidity in the room is below 60% RH.

If the fan always runs at boost:

- The setting of the humidity sensor has been set to the minimum. Change the setting.
- The level of humidity in the room is above 90% RH.

ECO DMEV+ HTP

Eco dMEV+ version similar to HT model, fitted with a manual pull cord to operate the boost when the humidity level is below the set point (fig.6).

When switching the pull cord off, the fan will continue to operate on boost for the time set by the timer then will revert to trickle speed, unless the humidity level exceeds the set point.

MAINTENANCE

IMPORTANT: disconnect from the mains supply before carrying out any maintenance.

The Eco dMEV+ extract fan is supplied with a plastic filter.

Performance depends on cleaning frequency and thus we recommend cleaning, minimum every two months, in accordance with fig 1a.

The Eco dMEV+ extract fan must always be operated with the filter fitted.

Using the extract fan without the filter invalidates the warranty.

The external surface of the fan only requires periodical cleaning using a cloth lightly impregnated with a soft detergent.

AFTER SALES SERVICE

We recommend you not to try to dismantle or remove any other parts than those mentioned as any tampering would automatically cancel the EnviroVent guarantee. If you detect any fault, contact our dedicated Technical team on 01423 810 810.

PUTTING OUT OF SERVICE AND RECYCLING



EEC legislation and our consideration of future generations mean that we should always recycle materials where possible; please do not forget to deposit all packaging in the appropriate recycling bins. If your device is also labeled with this symbol, please take it to the nearest Waste Management Plant at the end of its servicable life.

EnviroVent reserves the right to alter specifications without notice.



WARRANTY

The Eco dMEV+ products are covered by a two year warranty, subject to the specified maintenance stated within this booklet.

If your fan has been supplied and installed by EnviroVent it is covered with a full parts and labour warranty. If you detect a fault, please contact us on 01423 810 810. You will be given guidance over the phone, or an arrangement may be made for a member of our team to visit (call-out charges may apply if a fault cannot be identified).

Supply Only

If your fan has been supplied by EnviroVent and installed by a third party, it is covered by a parts only warranty. If you detect a fault and the product has been installed in accordance to the fitting/wiring instructions, relevant guidance documents and by a competent and qualified person (proof may be required), please return the product to the place of purchase for a replacement.

Warranty Conditions & Exclusions

Please note that a receipt will be required as proof of purchase. Fans bought from an unapproved source, including but not limited to auction websites, are not covered by the warranty.

- The system must be correctly installed and operated according to the instructions contained in the user guide supplied.
- The warranty will be rendered invalid if the system has been serviced, maintained, repaired, taken apart or tampered with by any person not authorized, which in any way contradicts the instruction guide set out by EnviroVent.
- The warranty does not cover accidental damage, misuse or abuse.
- The warranty is in addition to your statutory or legal rights.

envirovent

EnviroVent Ltd
Harrogate West Business Park
Unit 1 Bardner Bank
Killinghall
Harrogate
HG3 2SP

01423 810 810
info@envirovent.com

www.envirovent.com

Ref. 9023025210

